



## Installation of Toledo CR2 cleanroom panel systems

The aim of these instructions is to give the installer an idea of the correct technique to be employed for the installation and assembly of a typical Toledo CR2 system

### Tools:

The following tools represent a minimum requirement for successful installation. Alternatives can be used at the discretion of the installer, though it is not recommended. In the case of certain tools, such as spanners etc, it is worth remembering that the quality of each tool required will depend upon the scale of the installation and the number of people involved. In some cases further tools may be required.

- 

Drill + drill bits for: 4.2, 8, 10 & 12mm holes



Hacksaw





Screwdriver
- 

Power drill with hammer action



Hammer





Tape measure
- 

File



Pliers or mole grips





Spirit level
- 

Vacuum cleaner



Pop rivet gun



Adjustable spanner
- 

Metal Shears

Tek screw holder  
5mm Alan key

### Installation:

The following steps represent the correct order for the installation procedure.

- Identify all the components and label the parts where necessary.
- Prepare the surface upon which the panels are to be installed. The surface should be clean, smooth and level.
- Mark out the positions of all the panels, doors and posts.
- Install the floor channel.
- Install panels / mullions / doors.
- Fit top capping.
- Fit skirting.
- Fit roof panels if supplied.
- Fit top fascias if supplied.
- Check alignment and geometry of all panels before final tightening of all nuts and bolts.

## Before you begin

- Identify all the components for the installation and mark each with chalk or another non-permanent marking method.
- Choose a datum point from which to measure all the positions of the panels. A corner or point at the base of a wall is ideal and should be marked in a way that cannot be erased accidentally.
- Measure and mark the position for the installation. Remember to allow for the width of the joints between the panels and posts. A little care at this point can save a great deal of time later on.

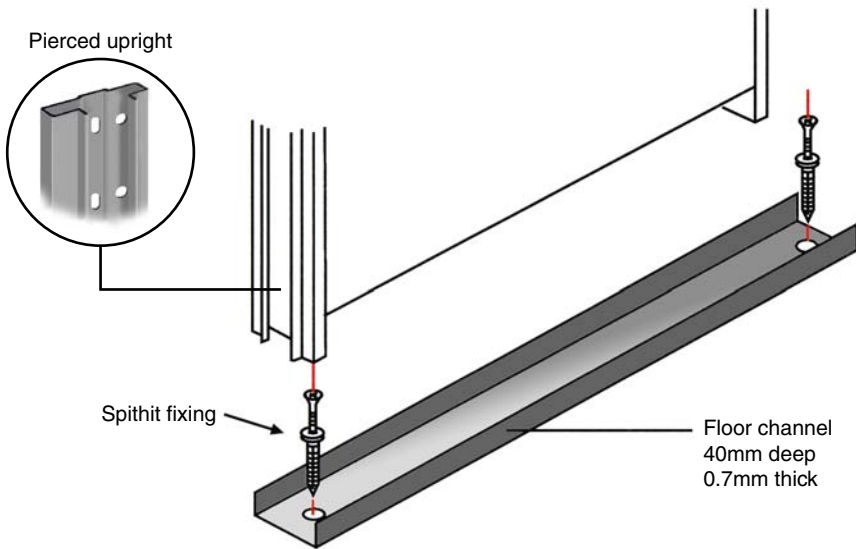

### Initial installation

Cut the lengths of floor channel to the correct size for the bottom of the panels. Remember to leave spaces in the floor channel for mounting mullions and doors.

Position the floor channel and drill holes through the channel into the floor at approximately 1m intervals. These holes must be 6mm diameter and at least 45mm deep.

Re-check that the floor channel is in the correct position and push spithit fixings through the holes in the channel into the floor.

Gently hammer the head of the fixing until only 5mm of the screw is proud of the base of the channel.

Screw the remainder of the fixing in using a crosshead screwdriver.

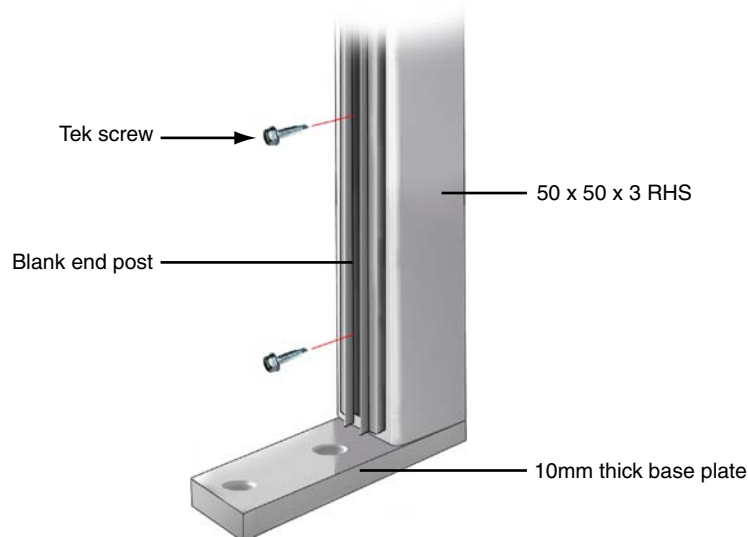

### Assembling mullions

The mullions come supplied in 2 parts. The first part consists of a length of RHS with a base plate welded to one end. The second part is a length of formed steel known as a blank end post.

Before the mullions are fitted they must be assembled. To do this use the tek screws to secure the blank end post to the mullion, ensuring it is positioned centrally.

All mullions should be prepared before further assembly is attempted.

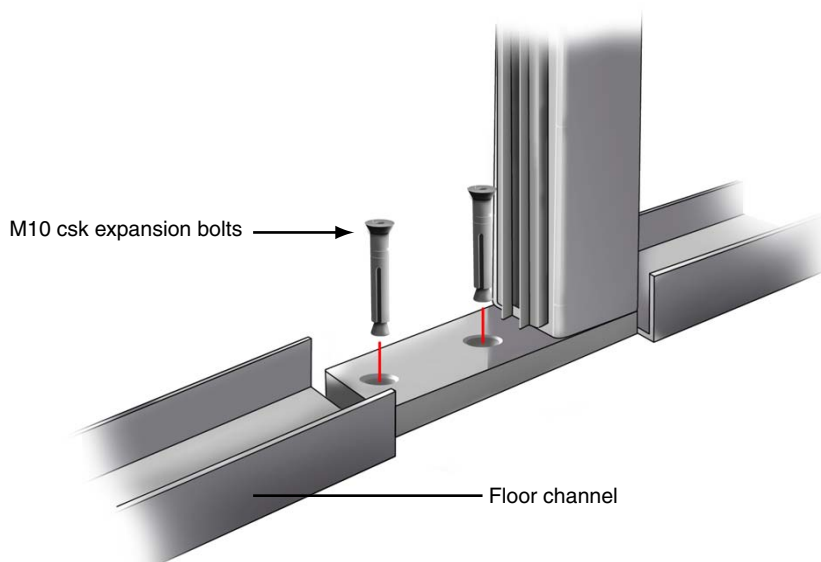

### Mounting mullions

The mullions are mounted to the floor using M10 threaded expansion bolts.

Position the mullion and, using the holes in the base plate as guides, drill 12mm diameter holes into the floor. These holes should be at least 120mm in depth.

Remove the mullion and clean away the excess dust from the drilling. Replace the mullion and push the expansion bolts through the base plate into the hole in the floor. A hammer may be required to gently drift the expansion bolt into the hole.

Check to ensure the mullion is vertically level at this stage as any discrepancy will be duplicated in the panels. If the mullion is not level packing can be used between the floor and base plate to correct it.

Tighten the bolts and re-check the alignment.

## Creating joints with panels and posts

There are 3 types of joints used when joining panels and / or posts:

- Panel, panel straight joint.
- Panel, post straight joint.
- Panel, preformed corner joint.

All the joints are constructed using the same group of components and the same techniques.

**H - Cleat**  
3mm thick mild steel

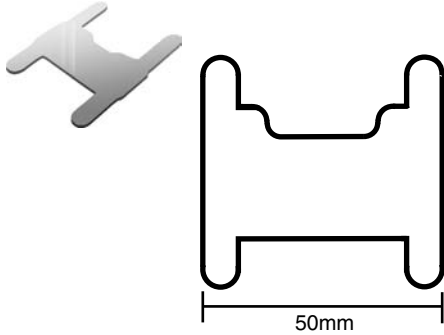

**Cover channel with spring clip**  
0.9mm thick mild steel

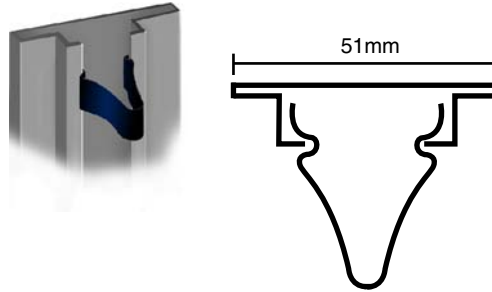

**Pierced Upright**  
0.9mm thick mild steel

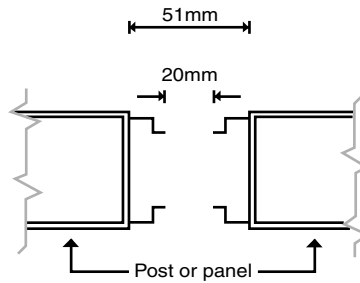
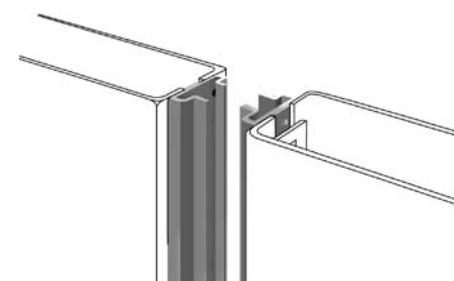
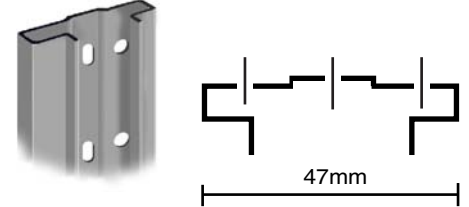

### Panel - panel or panel - post joint

Position the panel next to the panel / post to which it is to be joined. The base of the panel should rest in the floor track. The distance between the closest points of the panel should be ~20mm. The distance between the panel skins should be 51mm.

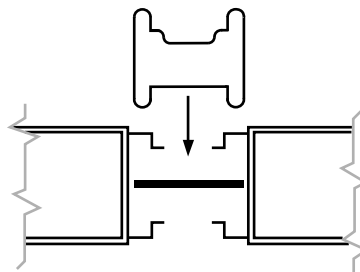
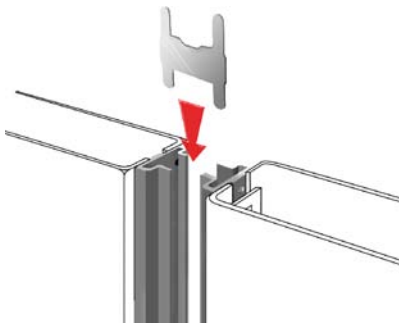

Slide a H-Cleat between the panels / posts by turning diagonally and rotating away from you. This will locate the H-Cleat between the centres of the Pierced Uprights.

Rotate the H-Cleat until it locks in place. Repeat this process until sufficient H-Cleats are in place. It is recommended that:

- 2440mm panel - use 5 H-cleats
- 2745mm panel - use 6 H-cleats
- 3050mm panel - use 7 H-cleats

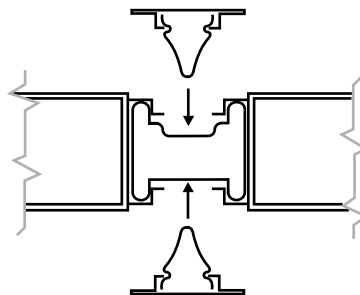
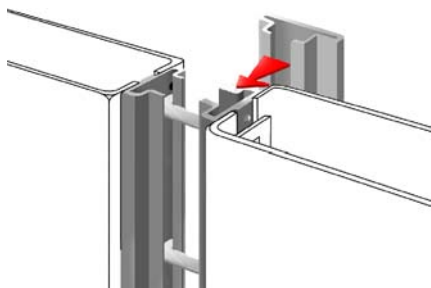

Fit the cover channels on both sides of the joint. 5 - 6 clips are used, equally spaced on each channel. Clip in the cover channel from top to bottom.

**Please note:**  
It is important to fit the cover channels as the panels are erected. Failing to do this may result in fitting problems.

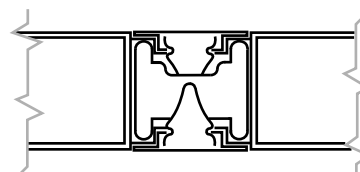
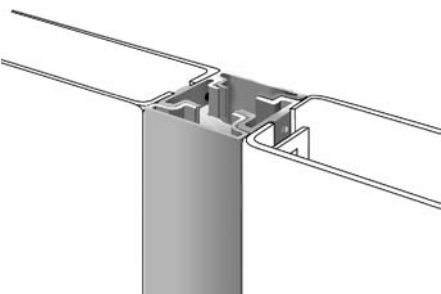

Finished panel - panel / panel - post joint.

## Fitting pre-formed corners

Panels fit to the pre-formed corners using the standard H-clip and cover channel method shown on the previous page. There are two types of pre-formed corner sections, shown below.

2-way 90 degree section

3-way T-section

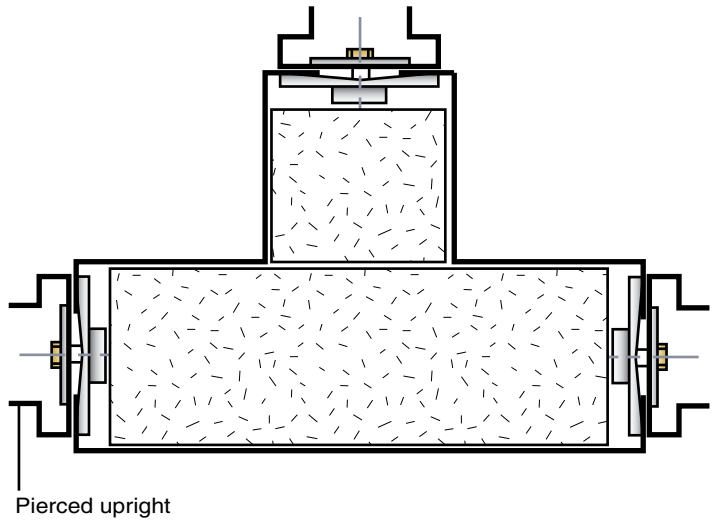
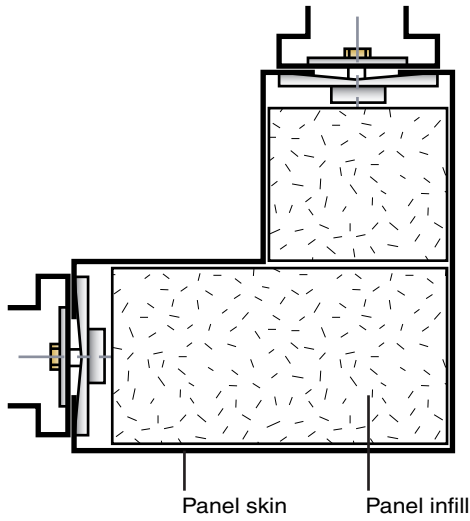

## Fitting top capping

There are various types of top capping (shown below) which may be supplied depending upon the application of the cleanroom partitioning.

Ceiling supporting top capping applications - supported ceilings

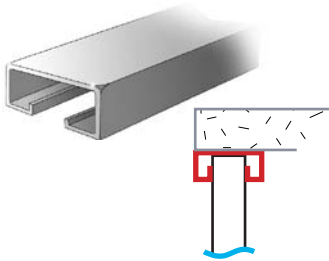

Heavy duty top capping applications - double lifts & free standing partition

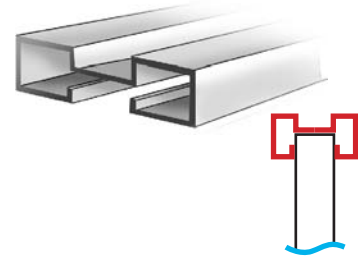

Drop in ceiling top capping applications - short span ceilings

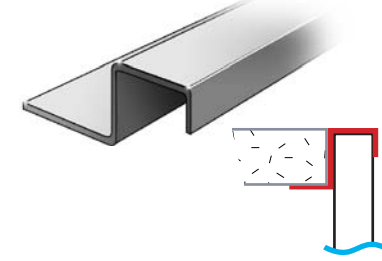

Top channel applications - floor to ceiling

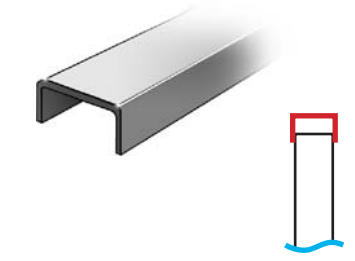

Top Capping 1.5mm thick mild steel

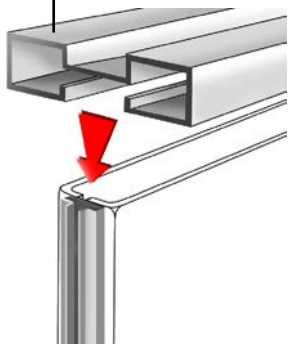

Joint cover 0.7mm thick mild steel

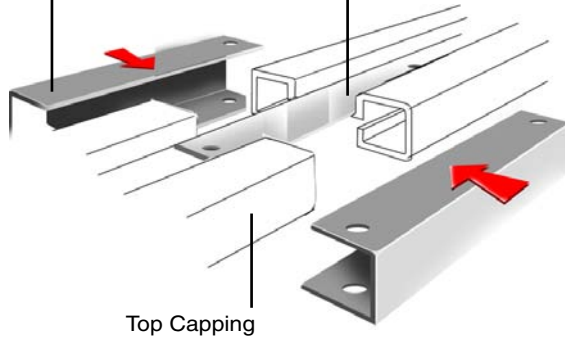

Top Capping

Corner Cover 0.7mm thick mild steel

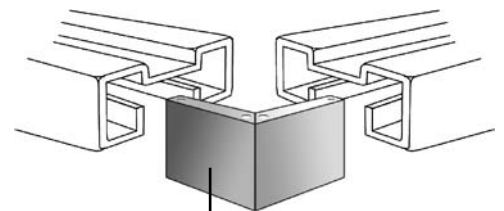

Cut the top capping to correct length and place on the top of the panel.

Where joints occur a splicing strip and joint covers are pop riveted to the top capping to add strength.

At corners a corner cover is applied to neaten the joint. This must be bent to match the angle of the corner. These are pop riveted to the top capping

# Fitting Double Skin Ceiling

When a double skin ceiling is being used with the partitioning a different top capping is used. It is fitted in the same way as the standard top capping. The roof also consists of tongued roof panels and Z-section.

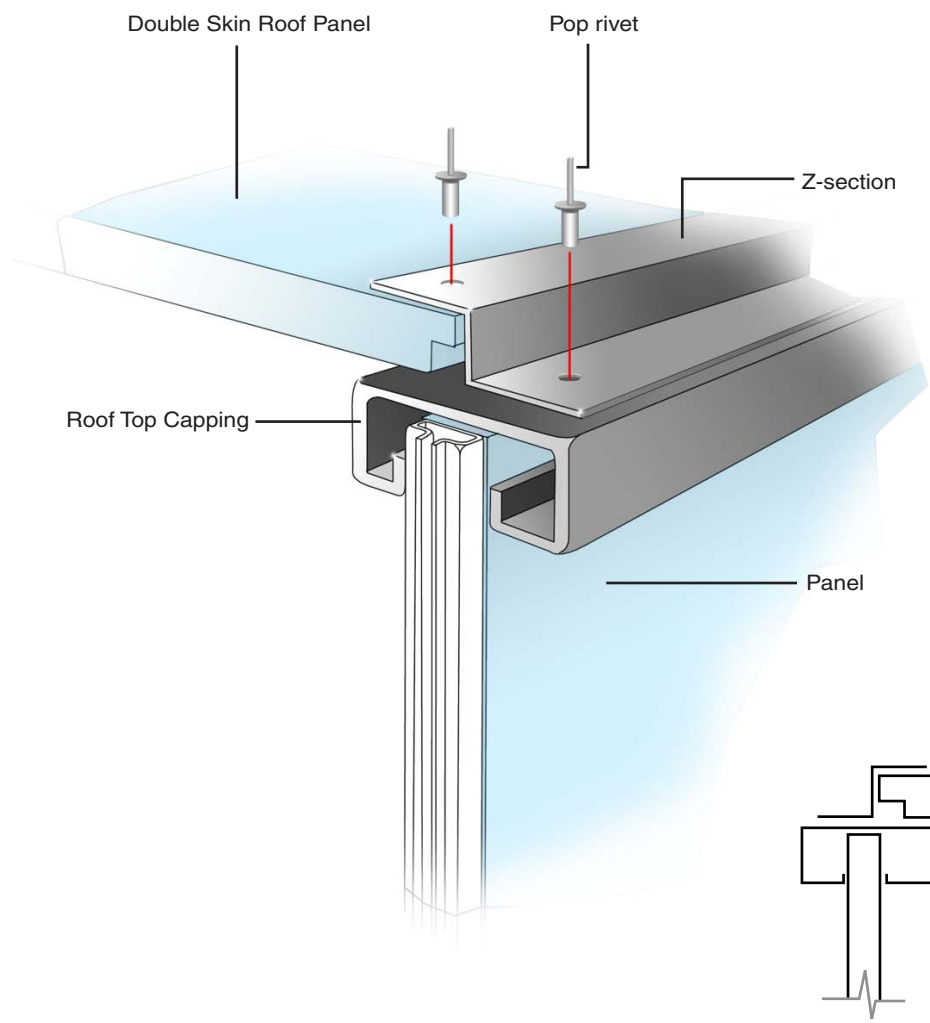
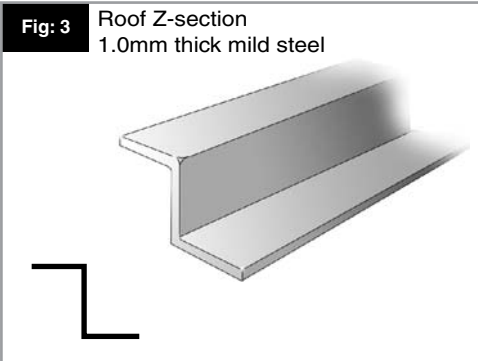
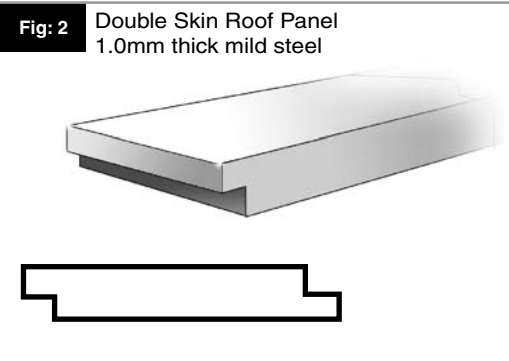
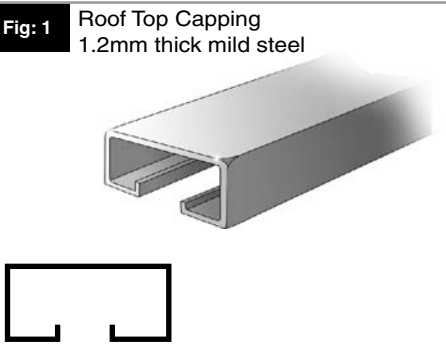

Fit the Roof Top Capping as usual. (see page 4)

Place the Double Skin Roof Panels (fig: 2) on top of the partitioning and arrange according to the manufacturing drawing.

Identify and cut the Z-section (fig: 3) to length and place around the edge of the roof so that it covers the outside edges of the roof panels.

Drill 6mm holes through the Z-section into the Roof Top Capping (fig: 1) and through the Z-section into the Double Skin Roof Panel. These holes should be drilled at approximately 1m intervals around the Z-section.

Pop rivet the Z-section to the Roof Top Capping and Double Skin Roof Panels.

If desired, extra screws can be used to join the Double Skin Roof Panels to each other though this is not strictly necessary.

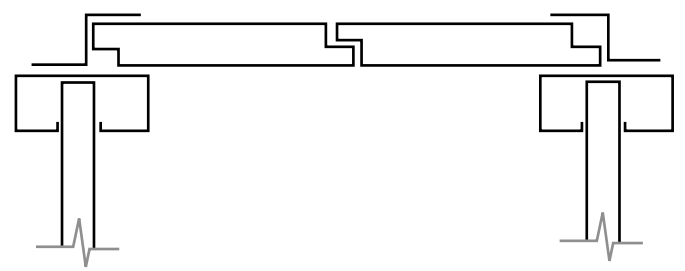

# Fitting hinged doors

Installing hinged doors is extremely simple. The single hinged doors are pre-assembled during manufacture and should not require further assembly other than glazing if appropriate. If glazing is to be fitted by the customer all glazing components will be supplied in the correct position or ready to use. The glazing technique will vary depending on the thickness, quantity and type of glazing material used. To all intents and purposes the installation of hinged doors can be treated in exactly the same way as a standard Toledo partition panel.

\*

Please note, however, that to ensure safe transit from works to site a steel strip is often fixed between the bottoms of the frame uprights. This piece of metal is purely for packaging purposes and should always be removed before installation, otherwise it will prevent the correct fitting of the frame.

# Fitting Exterior Skirting

Concealed Fixing  
2mm thick Aluminium

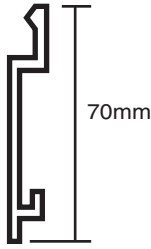

Aluminium Skirting  
2mm thick Aluminium

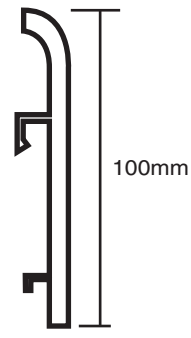
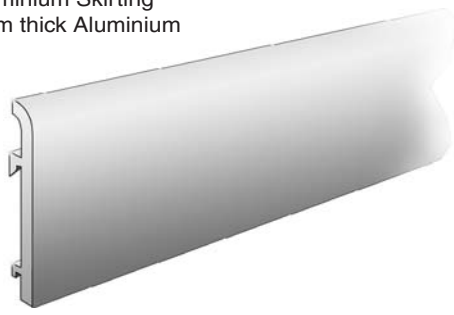

Drill holes in each of the concealed fixing components as shown in the diagram.

Pop rivet the concealed fixings to the base of the panels at intervals of 1.5m.

(Note: The height the bottom side of the concealed fixing is placed from the floor is the same height the bottom of the aluminium skirting will be from the floor when installed.)

Place the aluminium skirting in position, slotting it into the concealed fixing as shown.

