

Installation of Sabre partition systems

The aim of these instructions is to give the installer an idea of the correct technique to be employed for the installation and assembly of a typical Sabre partition system

Tools:

The following tools represent a minimum requirement for successful installation. Alternatives can be used at the discretion of the installer, though it is not recommended. In the case of certain tools, such as spanners etc, it is worth remembering that the quality of each tool required will depend upon the scale of the installation and the number of people involved. In some cases further tools may be required.



Installation:

- Please note Sabre panels cannot be installed ready glazed. Please see page 5 'Glazing panels' before beginning

The following steps represent the correct order for the installation procedure.

- Identify all the components and label the parts where necessary.
- Prepare the surface upon which the panels are to be installed. The surface should be clean, smooth and level.
- Select an appropriate datum from which to take all measurements.
- Mark out the positions of all the panels, doors and posts.
- Install floor channel.
- Install panels / mullions / doors.
- Fit top capping.
- Fit roof panels if supplied.
- Fit top fascias if supplied.
- Check alignment and geometry of all panels before final tightening of all nuts and bolts.

Before you begin

- Identify all the components for the installation and mark each with chalk or another non-permanent marking method.
- Choose a datum point from which to measure all the positions of the panels. A corner or point at the base of a wall is ideal and should be marked in a way that cannot be erased accidentally.
- Measure and mark the position for the installation. Remember to allow for the width of the joints between the panels and posts. A little care at this point can save a great deal of time later on.

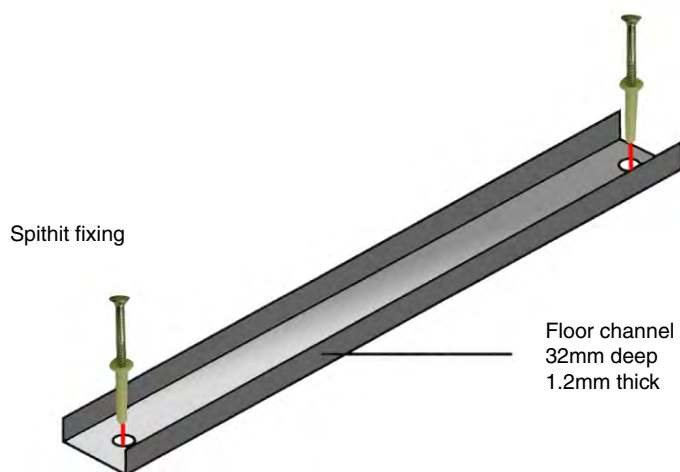

Floor channel

Cut the lengths of floor channel to the correct size for the bottom of the panels. Remember to leave spaces in the floor channel for mounting mullions and doors.

Position the floor channel and drill holes through the channel into the floor at approximately 1m intervals. These holes must be 6mm diameter and at least 45mm deep.

Re-check that the floor channel is in the correct position and push spithit fixings through the holes in the channel into the floor.

Gently hammer the head of the fixing until only 5mm of the screw is proud of the base of the channel.

Screw the remainder of the fixing in using a crosshead screwdriver.

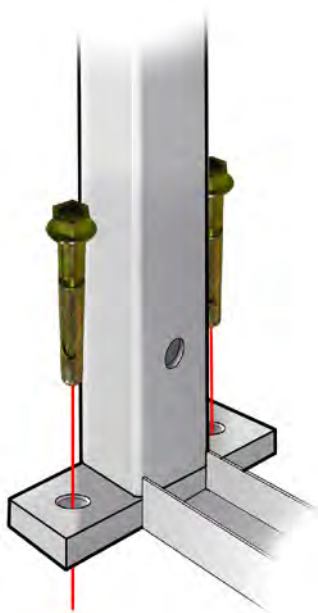

Mounting mullions

The mullions are mounted to the floor using M10 threaded expansion bolts.

Position the mullion and, using the holes in the base plate as guides, drill 12mm diameter holes into the floor. These holes should be at least 120mm in depth.

Remove the mullion and clean away the excess dust from the drilling. Replace the mullion and push the expansion bolts through the base plate into the hole in the floor. A hammer may be required to gently drift the expansion bolt into the hole.

Check to ensure the mullion is vertically level at this stage as any discrepancy will be duplicated in the panels. If the mullion is not level packing can be used between the floor and base plate to correct it.

Tighten the bolts and re-check the alignment.

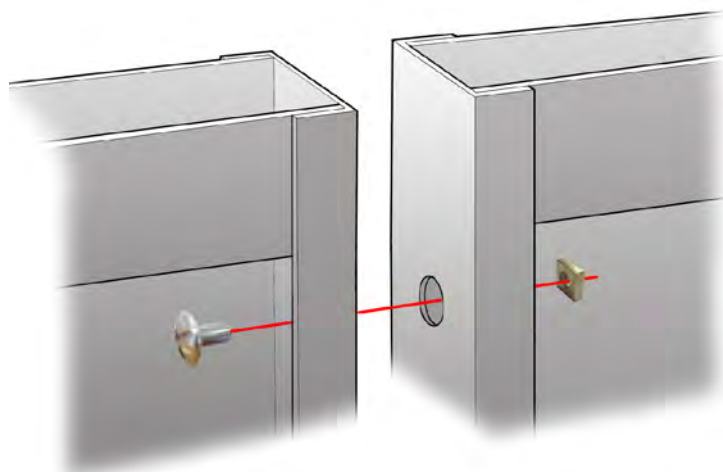

Panel to Panel

Position the panels in the desired position with the holes in each panel edge lined up.

Push a M6 x 12 Mushead bolt through the aligned holes and screw on a M6 nut.

Repeat this for all the holes. Check the position of the panels is still correct then tighten up nuts.

Using mullions

Mullions are used every three meters and for corners. There are three types for corners:

- 90 degree corner with 50mm x 50mm mullion
- 3 - way with a 50mm x 50mm mullion
- 50mm diameter post for angled corners

Straight joint with mullion

Position the first panel as required. Line up the mullion with the panel and check its position before fixing it to the floor.

Position the second panel so the holes line up correctly. When both panels are aligned with the mullion push through a M6 x 60 Mushead and screw on a M6 nut.

Repeat with all holes and check the final position of the panels before tightening the nuts fully.

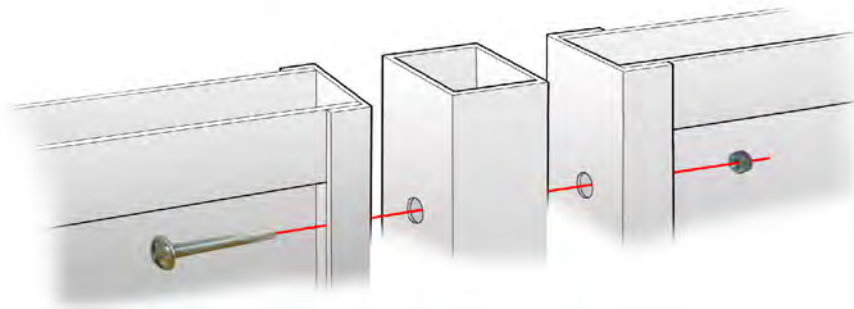

90 degree corner junction

Position the first panel as required. Align the corner post with the panel ensuring that it is vertically level as any discrepancy will be duplicated in the panels.

Fix the post to the panel by screwing M6 x 12 Mushead bolts into the tapped holes on the post. Repeat this process with the second panel.

Check to make sure the panels are level and vertical before tightening the bolts fully.

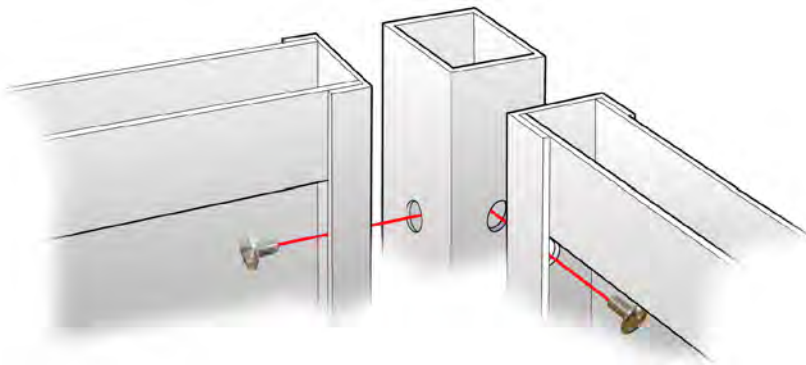

Circular post corner junction

Position the first panel as required. Align the circular corner post with the panel ensuring that it is vertically level.

Fix the post to the panel by screwing M6 x 12 Mushead bolts into the tapped holes on the post.

Position the second panel at the desired angle, put a washer on the tek screw and fix the panel to the post.

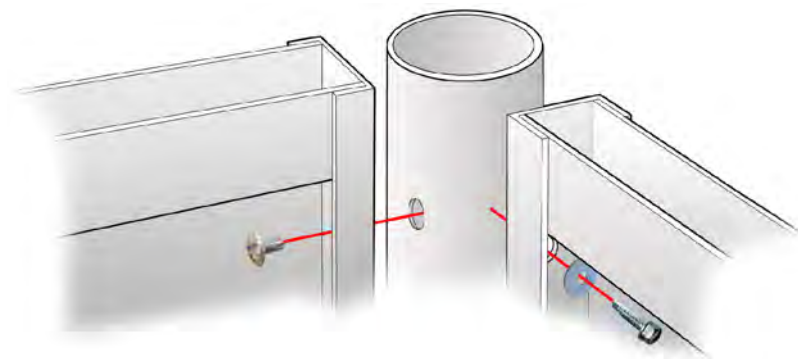

'T' junction

Position panel 1 as required, ensuring that it is square. Position the post and attach it to panel 1 with M6 x 12 Mushead bolts.

Align the panels 2 and 3 with the post checking that they are vertically level and that the holes in the post match up with the holes in the panel.

Once panels 2 and 3 are in position pass M6 x 60 Mushead bolts through panel 2, the post and panel 3. Ensuring that they are still square, attach M6 nuts.

Make one final check that all the panels are level before tightening all the nuts.

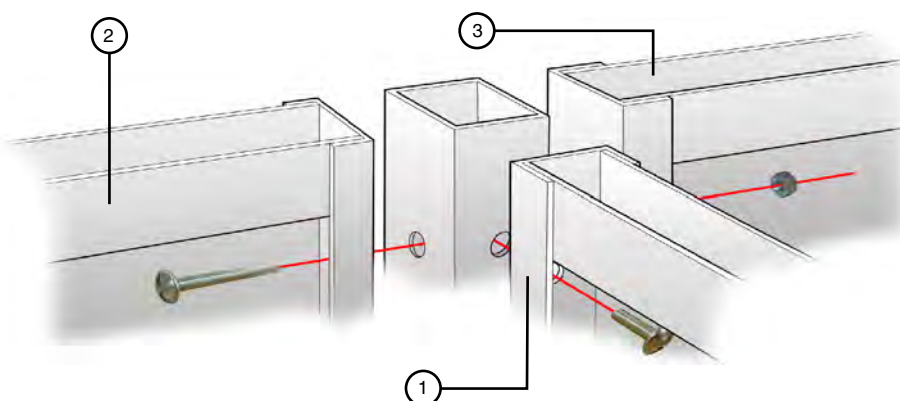

Door installation

- Remove threshold strip
- Fix frame
- Hang door

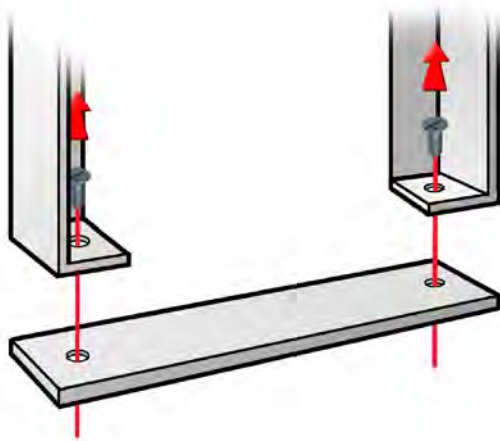

Before you begin

Identify the door and frame (these will be already screwed together) and the overpanel.

During transport a threshold strip is screwed to the bottom of the frame to make sure it is kept square. This is a disposable part and must be removed before starting installation.

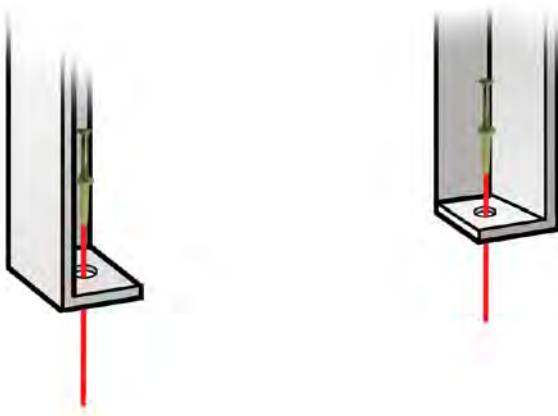

Fixing the frame to the floor

Position the door frame next to the adjacent panel or post and ensure that it is square. Using the holes in the bottom of the frame as guides holes drill 6mm diameter holes and at least 45mm deep.

Re-check that the frame is in the correct position and push spithit fixings through the frame into the floor. Gently hammer the head of the fixing until only 5mm of the screw is proud of the base of the channel.

Screw the remainder of the fixing in using a crosshead screwdriver.

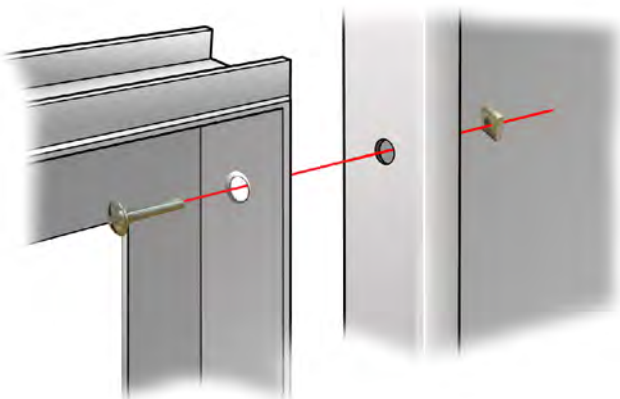

Fitting the doorframe

Fixing the doorframe uses the same principle as fixing together panels.

Position the door in the correct position next to the adjacent panel or post. Ensure that it is square and attach it using M6 x12 Mushead bolts and M6 nuts, making sure the head of the bolt is on the inside of the door to avoid the door catching.

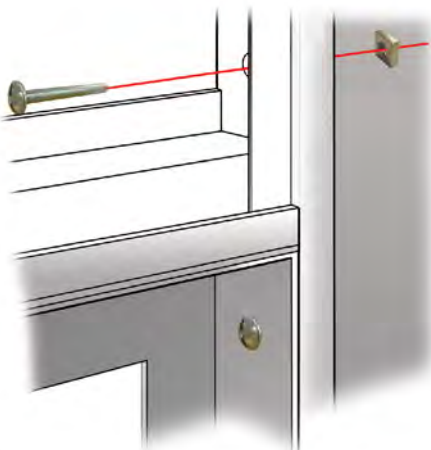

Fitting the overpanel

Place the overpanel in the 51 x 32 channel on top of the door frame and make sure it is square with the frame and adjacent panel.

Now bolt the overpanel to the adjacent panel using M6 x 12 Mushead bolts and M6 nuts.

Finishing

Final steps to installing Sabre partitioning are:

- Putting the glass in the glazed panels
- Fitting top capping

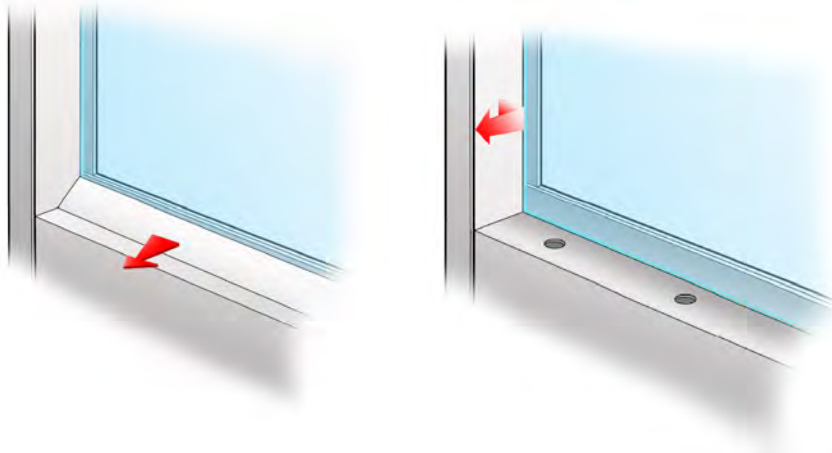

Glazing panels

Panels cannot be installed ready glazed because the glass will prevent the correct assembly of the mounting bolts that hold the panels together. As such any glazing should be removed before installation begins and replaced after the panels are assembled.

To remove the glazing first unclip the triangular glazing bead then remove the U channels from each side.

To replace the glazing first put in the glass followed by the U channels and finally clip in the triangular glazing bead to secure the assembly.

N.B. There is no glazing foam on the vertical edge of the inside of the glass



Fitting top capping

There are two main types of top capping (shown right) which are used with Sabre partitions:

A Heavy duty top capping is used for free standing partitions and double lifts.

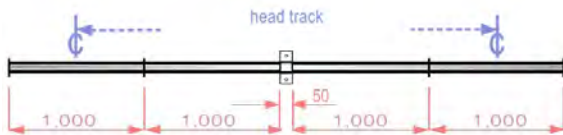

Standard top channel is used for normal floor to ceiling applications

Heavy duty top capping
applications - double lifts & free standing partition

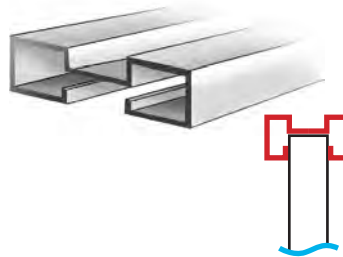

length: 3,200

Top channel
applications - floor to ceiling

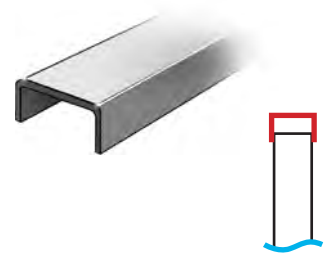

length: 3,000

Top Capping
1.5mm thick mild steel

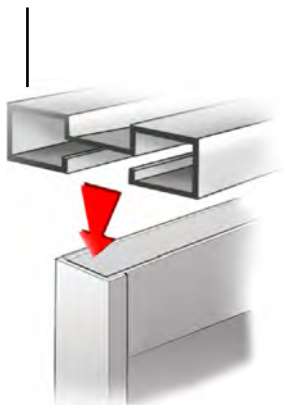

Cut the top capping to correct length and place on the top of the panel.

Joint cover
0.7mm thick mild steel

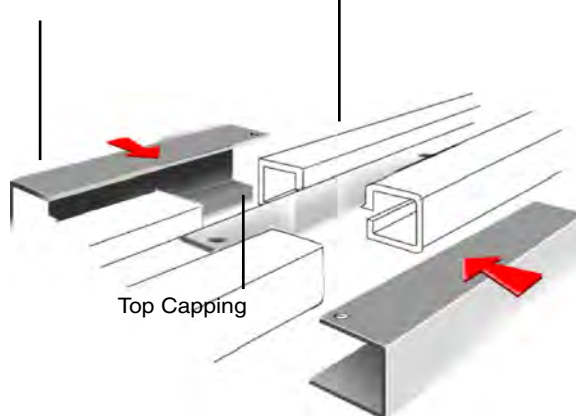

Where joints occur a splicing strip and joint covers are pop riveted to the top capping to add strength.

Splicing strip
3mm thick mild steel

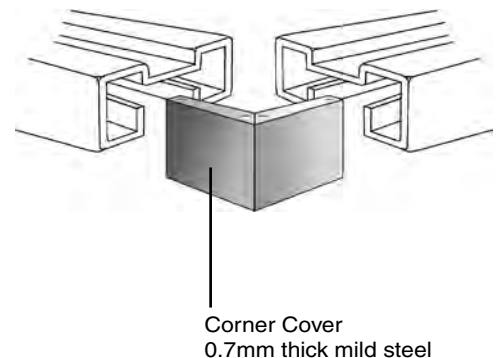

Corner Cover
0.7mm thick mild steel

At corners a corner cover is applied to neaten the joint. This must be bent to match the angle of the corner. These are pop riveted to the top capping