

Crossing Guard



PRODUCT DESCRIPTION

The Crossing Guard is installed in the upper areas of a warehouse to help prevent collisions at intersections.

When the vehicle or person approaches the intersection area it receives a visual alert from the traffic lights and the projection via the Bluespot or the VAS projector indicating whether he or she has permission to cross the intersection.

The Crossing Guard system uses radar technology capable of differentiating persons from vehicles and identifying whether a forklift is approaching an intersection or if it is moving away from it.

VERSIONS

Models with bluespot technology:

- PNC00580 CG 2S (2 faces with traffic lights)
- PNC00579 CG 3S (3 faces with traffic lights)
- PNC00578 CG 4S (4 faces with traffic lights)

Models with VAS System:

- PNC00583 CG V2S (2 faces with traffic lights)
- PNC00582 CG V3S (3 faces with traffic lights)
- PNC00581 CG V4S (4 faces with traffic lights)

TECHNICAL SPECIFICATIONS

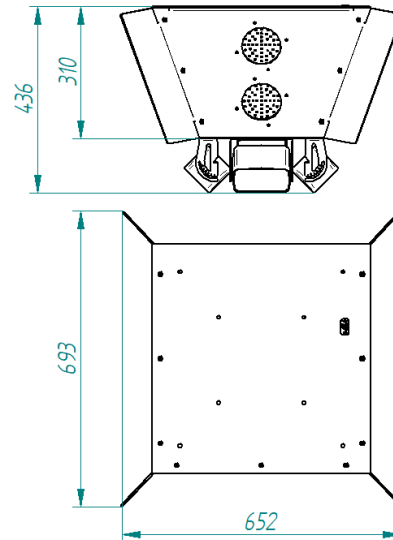

Dimensions: 820 mm x 820 mm x 640 mm

Weight:	25kg
Material:	Aluminium
IP protection:	IP 54
Mounting height:	From 3 to 7m
Speed max. detection:	Vehicle speed of 25km/h
Power supply:	100-240 VAC
Power:	120w (Crossing guard Bluespot) 240w (Crossing guard VAS)
Power supply connector:	IEC C6
T ^a Operating:	-10°C to +60°C
Packaging:	Wood box 820x820x640mm Weight: 30kg

Crossing Guard with bluespot



Crossing Guard with VAS Projector



Crossing Guard

ORDERING CODE

PNC00578 Crossing Guard 4S
(4 faces with traffic lights+ bluespot)

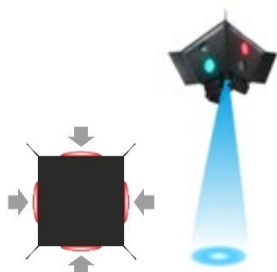

PNC00581 Crossing Guard V4S
(4 faces with traffic lights+ VAS projector)

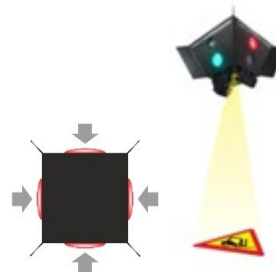

PNC00579 Crossing Guard 3S
(3 faces with traffic lights+ bluespot)

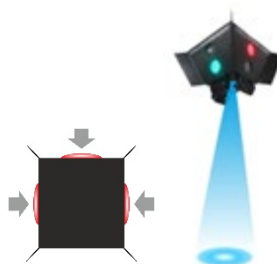

PNC00582 Crossing Guard V3S
(3 faces with traffic lights+ VAS projector)

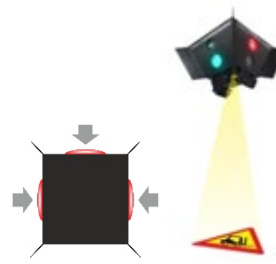

PNC00580 Crossing Guard 2S
(2 faces with traffic lights+ bluespot)

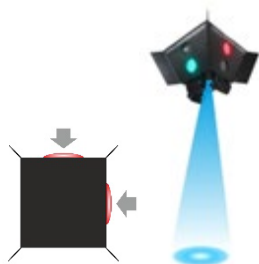

PNC00583 Crossing Guard V2S
(2 faces with traffic lights+ VAS projector)



Crossing Guard

ACCESORIES

Radar Crossing Guard:	PNC00603	
Remote Control Radar	PNC00758	
Loop Radar	PNC00782	
Radar loop support	PNC00862	
Ceiling Support	PNC00780	



This equipment may only be opened by qualified personnel. Handling or opening by unauthorized personnel may result in loss of warranty. The successful and good performance of this team says has been transported, stored.

