

D-FLEXX FLEXIBLE SAFETY BARRIER SYSTEM

CATALOGUE

PROTECTING PEOPLE, PROPERTY, AND PROCESSES



PART OF TROAX GROUP



HI THERE!

What do we want for every industrial and logistics facility?

We want safe employees, protected buildings and machines, and uninterrupted operations. They want fewer repairs and no unnecessary downtime.

d flexx delivers exactly that. We design smart, flexible safety systems that prevent accidents, protect infrastructure from impact, and significantly reduce repair costs. Our buffer pipe technology, modular design, and sustainable upcycling approach turn safety into measurable operational savings. Safety made simple, effective, and cost efficient.

TABLE OF CONTENT

Welcome

02

Smart Safety Solutions

04

Advanced PE Solution

06

Bufferpipe Technology

08

Our Services

10

The Design & Testing

12

Our Recycling Solutions & Sustainability

14

d-flexx Product Overview

16

Our projects

34



SMART SAFETY SOLUTIONS

Our customers want safety, reliability, and cost-efficiency. They want to keep their people safe, avoid damages to buildings, racks, and machines, and prevent costly downtime or repairs.

D-FLEXX DELIVERS EXACTLY THAT:

- Protects employees, infrastructure, and equipment from impacts and accidents
- Reduces repair and downtime costs with innovative bufferpipe technology
- Provides true modularity – easy to install, adapt, and extend
- Ensures durability: indoor & outdoor use, extreme temperature resistance, high UV-stability
- Supports sustainability with circular economy and upcycling solutions
- Guarantees quality with a 5-year warranty
- One for All – one system for all environments and applications

With d-flexx, safety becomes simple, sustainable, and cost-efficient.

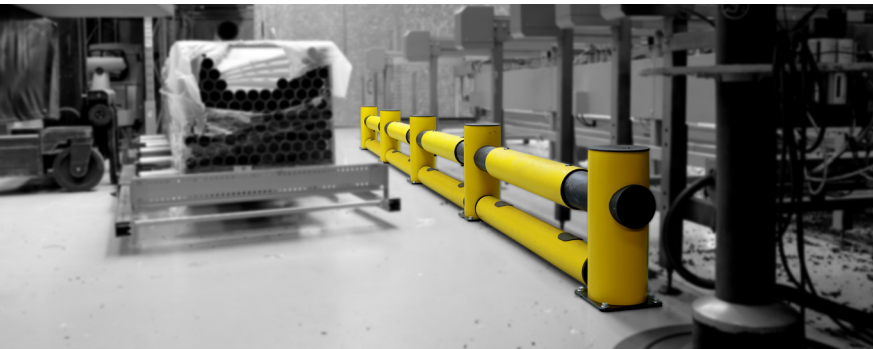

A MODULAR SYSTEM

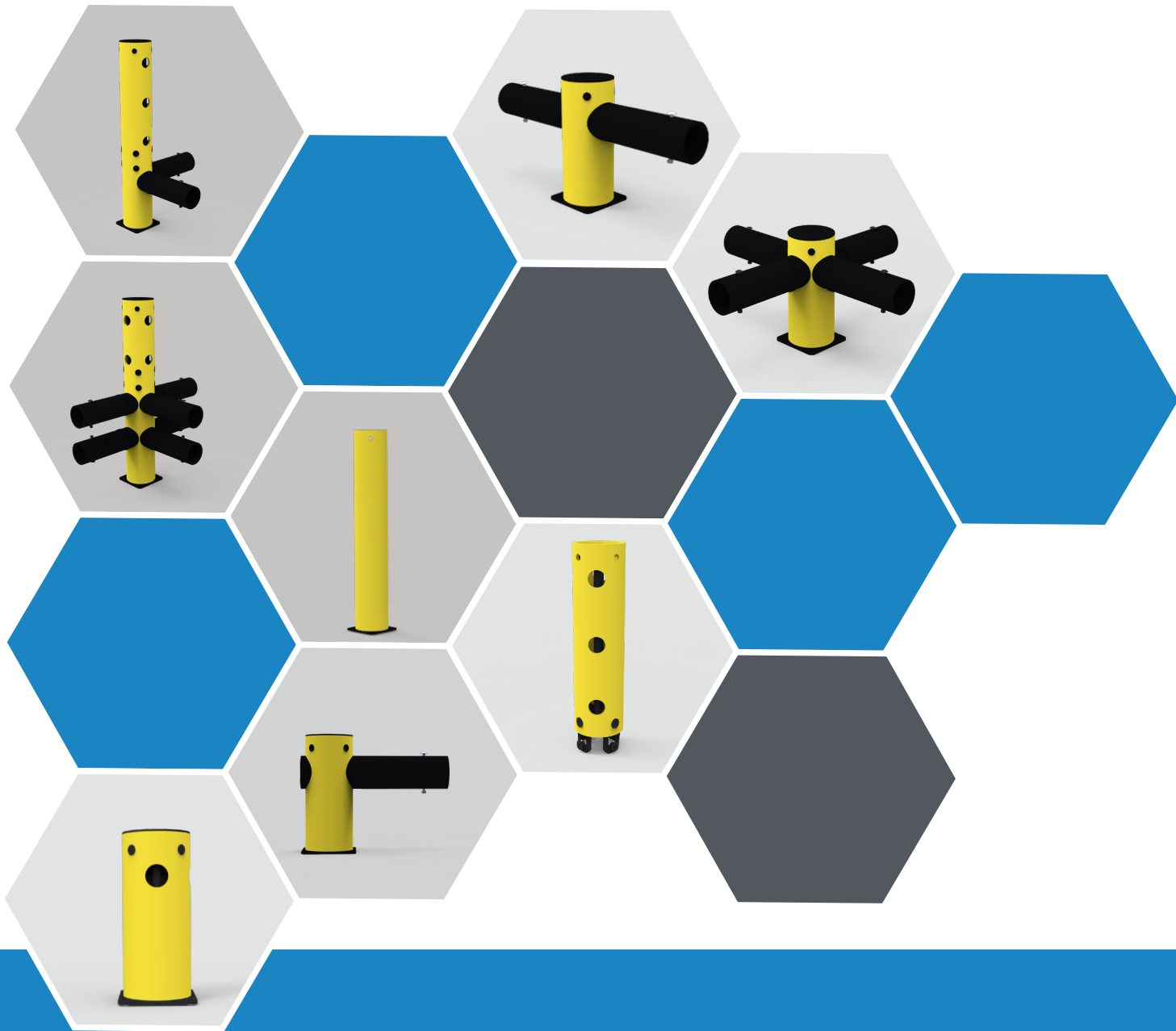

d-flexx safety systems are built on modularity, enabling rapid adaptation to the demands of modern industrial and commercial environments. This flexible design supports quick changes, whether expanding a facility, reorganizing work areas, or meeting new safety regulations. Modules can be reconfigured, extended, or integrated with

other components with minimal effort. Every system is engineered for full compatibility, ensuring smooth integration across the entire d-flexx range. The modular approach cuts installation time, simplifies upkeep, and delivers cost-effective scalability without compromising performance.

ADVANCED PE SOLUTION

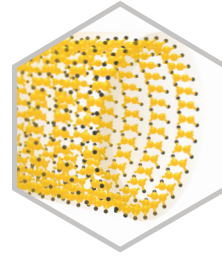

MINIMALIST DESIGN, MAXIMAL OUTPUT

Our unique advanced polymer structure engineered by our Research and Development department is exclusively found in the d-flexx product line. Its innovative design pushes the outstanding properties of polyethylene (PE) to their ultimate performance.

d-flexx offers the optimal balance between resistance and flexibility. During a collision, the barrier absorbs the energy, preventing damage to the colliding vehicle and the flooring. Moreover, PE has a native molecular memory that makes it reshape after an impact.

d-flexx materials are engineered to fully perform in every environment from indoor to outdoor settings, in both dry and humid conditions, and throughout temperatures from -40°C to 50°C . Polyethylene's chemical resistance and easy-to-clean surface makes it an ideal choice for hygienic environments.

d-flexx offers outstanding durability and leverages polyethene's excellent recycling properties, ensuring a sustainable lifecycle from production to disposal.

ONE FOR ALL

Indoor and outdoor use

Versatility is key with d-flexx. Whether indoors or outdoors, our products deliver consistent safety and protection, adapting seamlessly to various environments.

Cold and warm stores

From cold stores to warm environments, d-flexx safety barriers maintain their structure and performance regardless of extreme temperatures.

Wide temperature range

With a temperature range spanning from -40°C to $+50^{\circ}\text{C}$, d-flexx solutions persist in harsh environments, providing reliable safety measures regardless of the weather conditions.

UV-stability

Our products are engineered with UV-stable materials, ensuring longevity and reliability even in outdoor environments exposed to sunlight.





IMPACT PROTECTION EXPLAINED

As standard, d-flex foot plates are equipped with high-quality concrete screws, also known as concrete anchors or screw anchors. These specialized fasteners are precisely engineered for secure installation into concrete surfaces. With their threaded design, they cut firmly into the drill hole, ensuring strong and reliable anchoring for all d-flex products.

Every TÜV-tested d-flex product undergoes rigorous testing with these concrete screws to guarantee maximum performance and safety. An additional benefit is their flexibility – posts can be disassembled and reassembled multiple times, making repairs or replacements after barrier damage simple and cost-efficient.



What sets d-flex apart is the intelligent balance between strength and protection. With a pull-out resistance of 21 kN, our bolts are designed to release just before exceeding the strength of a standard concrete floor (21 kN per hole). This ensures that, in the event of extreme impact, the bolts give way before the floor itself is damaged - protecting your infrastructure while keeping your operations running smoothly.

Deflection Zone

Since the barrier absorbs an impact, there is a need for a deflection zone.

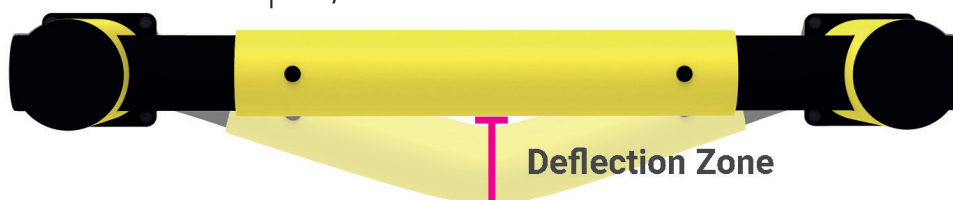

BUFFER PIPE TECHNOLOGY

Experience the power of d-flexx buffer pipe technology and elevate your safety standards today.

D-FLEXX BUFFER PIPE TECHNOLOGY INNOVATION AT THE CORE OF SAFETY

Embedded within every bollard and traffic barrier mid- and end posts lies a powerful innovation: d-flexx buffer pipe technology. This cutting-edge advancement features a robust core encased by buffer pipes, concealed within the structure.

As the name implies, the buffer pipes serve as an energy absorption zone between the outer pipe and the inner core. Collaborating seamlessly with the flexible d-flexx material, these buffer pipes culminate in a resilient, high-quality flexible post.

This unique design enables the post to absorb impacts effectively without causing damage to the concrete floor.

d-flexx buffer pipe technology represents a significant leap forward in safety and durability for bollards and traffic barriers. By incorporating this innovative solution, businesses and organizations can enhance their security measures while safeguarding their infrastructure from potential damage.



OUR SERVICES

At d-flexx, safety is not just a product – it's a service. From on-site consultation and professional training to smart planning tools, global delivery, and sustainable recycling, we support you at every step. Our goal: a safer, more efficient workplace tailored to your needs.

WE ADVISE

d-flexx has certified safety advisors who conduct on-site surveys and offer tailored advice to implement the right safety solutions for your workplace.



WE EDUCATE

Our Safety Academy educates our customers and partners in risk assessment and safety planning, fostering a strong safety culture.



WE DESIGN

Our d-flexx designer software allows fast, intuitive and detailed safety planning. Upload your warehouse blueprints and start planning your d-flexx solutions with ease.

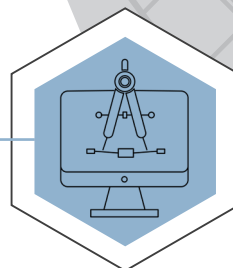

COMPREHENSIVE SAFETY SERVICES FROM PLANNING TO RECYCLING

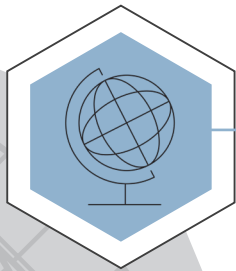

WE DELIVER

We ship worldwide directly from our production facilities or through our partner network, with the option of personalized installation services.

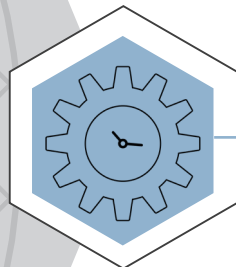

WE SUPPORT

Our after-sales service includes continuous support and a five-year warranty on every d-flexx product.

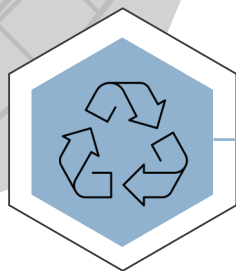

WE RECYCLE

Through our European Recycling Program, you can send back discharged d-flexx materials to our Denmark based facility for proper disposal and recycling.

THE DESIGN

Streamlined design, optimal performance

The precision-engineered d-flexx solutions embody our approach of doing more with less. Our reliable, streamlined pipe system, built on lean geometry, reduces costs and effort across the entire value chain. It cuts material use in manufacturing, lightens transport loads, and simplifies assembly with fewer components.

This design philosophy ensures full compliance with the highest safety standards. The system delivers strong impact resistance, long-term reliability, and consistent performance across a wide range of operating conditions.

Preventing accidents with behavioral design

At d-flexx, we believe safety starts with behavior and consistent habits. By understanding how people move and interact with their environment, we design solutions that make safe actions intuitive and help prevent accidents.

This mindset is built into every detail—from the vivid yellow colour for high visibility and clear signalling to the strategic placement of our barriers, which structure spaces and guide pedestrian and vehicle flows naturally. This approach reduces the need for constant oversight, supports lasting compliance, and combines safety performance with operational efficiency.

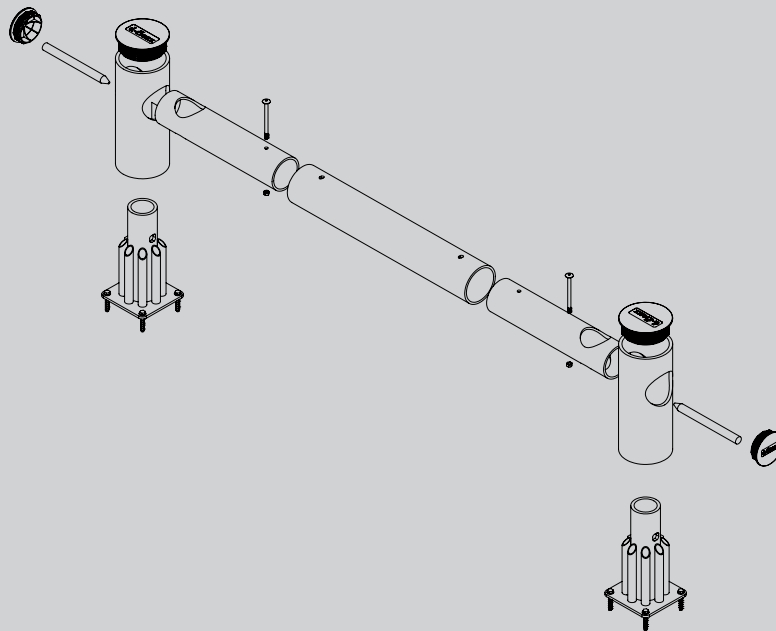

Safety meets efficiency: Intuitive design for maximum impact protection

d-flexx solutions optimize behavior, reduce effort, and enhance safety – without compromise.

OUR TESTING METHOD

Every d-flexx bollard and barrier undergoes rigorous evaluation using a pendulum striker, in full alignment with BSI's PAS 13:2017 code of practice. A fixed bumper on a swinging arm delivers controlled, repeatable impacts. Each unit is assessed multiple times to ensure consistent performance, with precise instrumentation capturing key data. All results are documented and traceable.

We base our evaluation on real-world impact scenarios observed in industrial environments. These insights define how force is applied during testing, allowing us to closely replicate the actual conditions our barriers are designed to withstand.

PAS.13: 2017 IN SHORT

PAS means Publicly Available Standards.

It is created by the British Standards Institute to promote the best practices in the industry.

The current standard was created in 2017.

PAS 13: 2017 covers:

- Normative references
- Safety barriers used in traffic management
- General safety barriers design
- Kinetic energy and vehicles
- Methods for testing the force of impact of safety barriers



Third-party certification

Beyond internal validation, d-flexx products are certified by TÜV Nord, an independent and internationally recognised authority. This certification verifies the accuracy, repeatability, and reliability of our evaluation process and confirms full compliance with stringent safety and quality standards.

Under TÜV supervision, products are conditioned in a controlled environment for at least four hours before testing to ensure stable, comparable results. This audited approach is reinforced by our ISO 9001 accreditation, confirming excellence in quality management.

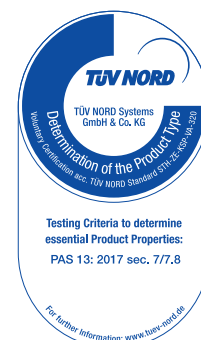

D-FLEXX RECYCLING SOLUTIONS

Highly recyclable materials

d-flexx safety solutions combine high-density polyethylene (HDPE) and low-density polyethylene (LDPE), both offering high and documented recyclability.

HDPE is one of the most widely recycled polymers, commonly reused in products such as bottles, pipes, and floor decking.

Our choice of polyethylene reflects a commitment to combining impact resistance and versatile performance with a responsible product life cycle and material circularity.

Recycle – because smart protection never ends with impact.



We help you recycle d-flexx materials

A broken barrier? Need to renew your protections? Sometimes it simply means d-flexx did its job - it protected as it should, and now some parts need replacement. As part of our after-sales support, d-flexx offers the option to return used materials to our Danish headquarters in Slangerup.

In coordination with local recycling streams, we ensure that every d-flexx component is properly handled and reintegrated into a responsible recycling process. For more information or to arrange a return and to hear more about our special offer for replacement orders, please contact your d-flexx sales representative.

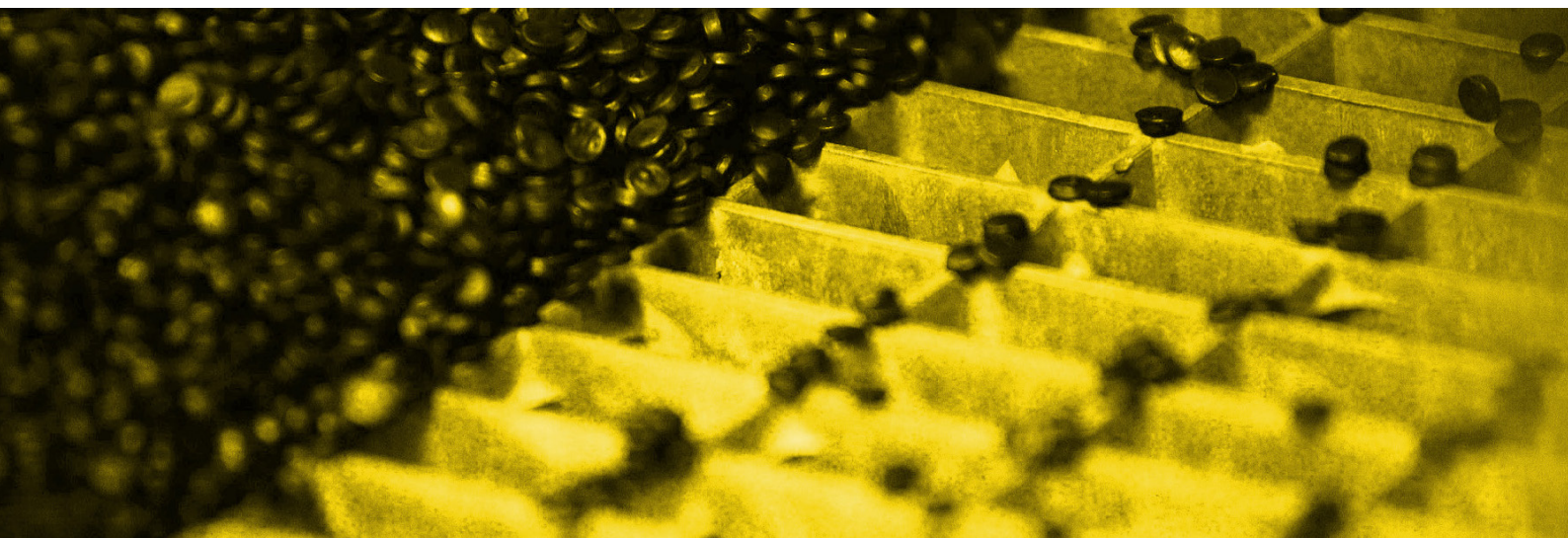

OUR SUSTAINABILITY



REUSABILITY & DISASSEMBLY

- Our systems are modular and easy to reconfigure for evolving warehouse needs.
- Clear guides help customers dismantle and recycle components.
- Individual parts can be replaced to reduce waste and cost.

As part of the Dancop Group, sustainability is far more than a passing trend at d-flexx – it is a core value that drives our daily actions and long-term strategy. From product development to delivery, we are committed to creating solutions that not only protect people and infrastructure, but also respect and preserve the environment.

Our modular safety systems are engineered with purpose: to deliver high performance while reducing ecological impact. This includes using recyclable materials, minimizing production waste, and designing products that can be reused, reconfigured, and easily recycled at the end of their life cycle.

Durability, circular design, and transparency form the foundation of our sustainability approach. By actively reducing emissions, extending product lifespans, and collaborating with responsible suppliers, we take meaningful steps toward a safer and greener future.

At d-flexx, we believe true safety includes the well-being of our planet – for today, tomorrow, and the generations ahead.

Our mission: Creating safer environments with fewer environmental footprints. Because true progress combines innovation with responsibility.

PEDESTRIAN SEGREGATION

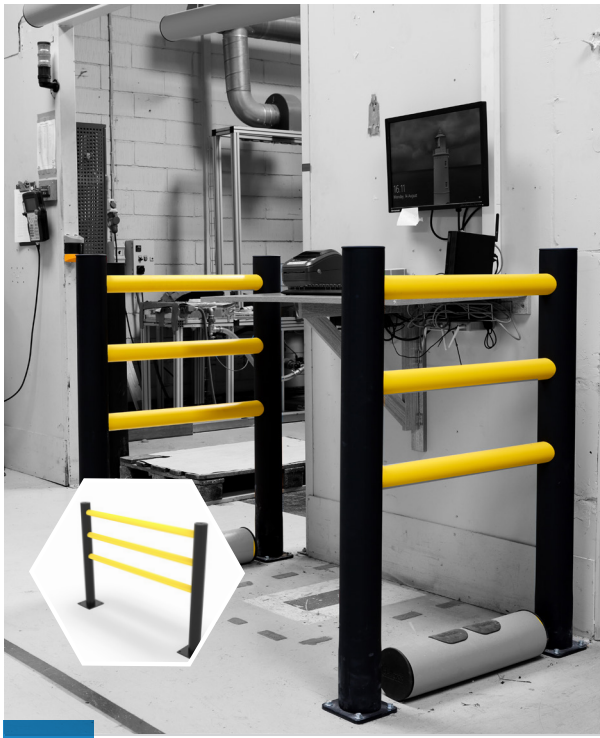

PEDESTRIAN GUARDRAIL

The Pedestrian Guardrail prevents exposure to hazardous areas by channelling worker movement through designated walkways. It outperforms ground markings in industrial and logistics settings by physically directing movement. Its streamlined polyethylene design ensures low maintenance and easy installation indoors and outdoors.

TECHNICAL INFORMATION

| | |
|--------------------------------------|--|
| Operational Temperature Range: | -40°C up to +50°C / -40°F up to +112°F |
| Ignition Temperature: | 350-360°C / 662 - 680°F |
| Flash Point: | 350-360°C / 662 - 680°F |
| Toxicity: | Nontoxic |
| Chemical Resistance: | High-ISO / TR 10358 |
| UV Stability | Gray scale: 5/5 |
| Changes to material after 5 years: | Blue Wool scale: 8/8 Tensile strength: No changes |
| Static Rating (surface resistivity): | 10^{15} - $10^{16} \Omega$ |
| Standard Warranty: | 5 Years |
| Fixations: | Concrete screw, Zinc coated, Size $\varnothing 10 \times 70$ mm |
| Deflection zone: | 250mm / 9,84in |

IMPACT TEST

| | | |
|-------------------------------------|-------|-------|
| Mid Rail Max. Energy (Joules) | 90° | 45° |
| | 3.000 | 6.000 |
| End post max. energy (Joules) - 90° | | 2.500 |
| Mid post max. energy (Joules) - 90° | | 2.500 |

MAX. FORCE TO BOLT

DELTA: 13 kN

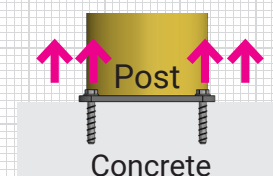



PEDESTRIAN GATE

The Pedestrian Gate channels movement from safe walkways into mixed traffic areas, resulting in a measured level of risk exposure. Combined with Pedestrian Guardrails and Barriers, it forms an integrated guidance system that ensures smooth traffic flow and maximum safety. An optional metal gate stop and self-closing hydraulic hinges enable safe and intuitive use.

TECHNICAL INFORMATION

| | |
|--------------------------------------|--|
| Operational Temperature Range: | -40°C up to +50°C / -40°F up to +112°F |
| Ignition Temperature: | 350-360°C / 662 - 680°F |
| Flash Point: | 350-360°C / 662 - 680°F |
| Toxicity: | Nontoxic |
| Chemical Resistance: | High-ISO / TR 10358 |
| UV Stability | Gray scale: 5/5 |
| Changes to material after 5 years: | Blue Wool scale: 8/8 Tensile strength: No changes |
| Static Rating (surface resistivity): | 10^{15} - $10^{16} \Omega$ |
| Standard Warranty: | 5 Years |
| Fixations: | Concrete screw, Zinc coated, Size $\varnothing 10 \times 70$ mm |

PEDESTRIAN SEGREGATION



PEDESTRIAN POST

The Pedestrian Post marks personnel presence in mixed traffic environments. It is well-suited for zones intermittently crossed or occupied by pedestrians, such as workstations, control panels, or access points. Easy to install, these highly visible yellow posts help prevent accidents by improving driver awareness.

TECHNICAL INFORMATION

| | |
|--------------------------------------|--|
| Operational Temperature Range: | -40°C up to +50°C / -40°F up to +112°F |
| Ignition Temperature: | 350-360°C / 662 - 680°F |
| Flash Point: | 350-360°C / 662 - 680°F |
| Toxicity: | Nontoxic |
| Chemical Resistance: | High-ISO / TR 10358 |
| UV Stability | Gray scale: 5/5 |
| Changes to material after 5 years: | Blue Wool scale: 8/8 Tensile strength: No changes |
| Static Rating (surface resistivity): | 10^{15} - $10^{16} \Omega$ |
| Standard Warranty: | 5 Years |
| Fixations: | Concrete screw, Zinc coated, Size $\varnothing 10 \times 70$ mm |

IMPACT TEST

Bollard max. energy 1.500

MAX. FORCE TO BOLT

DELTA B: 13 kN

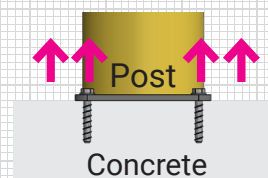

MAX. INCLINATION ANGLE 15°





TOPPLE GUARDRAIL

The Topples Guardrail reduces pedestrian injury risk by preventing goods stored at height from falling. It is ideally positioned where walkways are adjacent to racking systems. This modular system, built from stackable units, allows customised length and height, up to 4.2 metres.

TECHNICAL INFORMATION

| | |
|--------------------------------------|--|
| Operational Temperature Range: | -40°C up to +50°C / -40°F up to +112°F |
| Ignition Temperature: | 350-360°C / 662 - 680°F |
| Flash Point: | 350-360°C / 662 - 680°F |
| Toxicity: | Nontoxic |
| Chemical Resistance: | High-ISO / TR 10358 |
| UV Stability | Gray scale: 5/5 |
| Changes to material after 5 years: | Blue Wool scale: 8/8 Tensile strength: No changes |
| Static Rating (surface resistivity): | 10^{15} - 10^{16} Ω |
| Standard Warranty: | 5 Years |
| Fixations: | Concrete screw, Zinc coated, Size Ø10x70 mm |

IMPACT TEST

End post max. energy (Joules) - 90° 4.000

Mid post max. energy (Joules) - 90° 4.000

MAX. FORCE TO BOLT

DELTA B: 21 kN

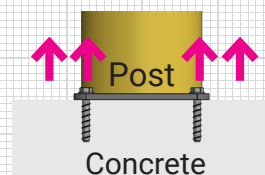

PEDESTRIAN PROTECTION



PEDESTRIAN BARRIER



The Pedestrian Barrier reduces personnel injury risk by providing impact protection against vehicles. It is used in mixed traffic environments to separate walkways and workstations from driving lanes.

Made of flexible polyethylene, the barrier absorbs impacts by bending and returning to its original shape. Its elasticity allows repeated impacts while reducing pressure on concrete flooring, helping prevent costly repairs and downtime.

TECHNICAL INFORMATION

| | |
|--------------------------------------|--|
| Operational Temperature Range: | -40°C up to +50°C / -40°F up to +112°F |
| Ignition Temperature: | 350-360°C / 662 - 680°F |
| Flash Point: | 350-360°C / 662 - 680°F |
| Toxicity: | Nontoxic |
| Chemical Resistance: | High-ISO / TR 10358 |
| UV Stability | Gray scale: 5/5 |
| Changes to material after 5 years: | Blue Wool scale: 8/8 Tensile strength: No changes |
| Static Rating (surface resistivity): | 10 ¹⁵ -10 ¹⁶ Ω |
| Standard Warranty: | 5 Years |
| Fixations: | Concrete screw, Zinc coated, Size Ø12x80 mm |
| Deflection zone: | 250mm / 9,84in |

IMPACT TEST

| | 90° | 45° |
|-------------------------------------|-------------------------------|-------|
| | Mid Rail Max. Energy (Joules) | 9.000 |
| End post max. energy (Joules) - 90° | 4.000 | |
| Mid post max. energy (Joules) - 90° | 4.000 | |

MAX. FORCE TO BOLT

ECHO: 21 kN

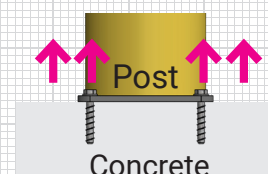



PEDESTRIAN BARRIER DOUBLE



The Pedestrian Barrier Double reduces personnel injury risk by providing impact protection against heavy-duty traffic. It is suited for environments where high-capacity vehicles such as yard tractors and shunt trucks operate near pedestrian walkways.

Made of flexible polyethylene, the barrier absorbs impacts by bending and returning to its original shape. Its elasticity allows repeated impacts while reducing pressure on concrete flooring, helping prevent costly repairs and downtime.

TECHNICAL INFORMATION

| | |
|--|---|
| Operational Temperature Range: | -40°C up to +50°C / -40°F up to +112°F |
| Ignition Temperature: | 350-360°C / 662 - 680°F |
| Flash Point: | 350-360°C / 662 - 680°F |
| Toxicity: | Nontoxic |
| Chemical Resistance: | High-ISO / TR 10358 |
| UV Stability Changes to material after 5 years: | Gray scale: 5/5 Blue Wool scale: 8/8 Tensile strength: No changes |
| Static Rating (surface resistivity): | 10^{15} - $10^{16} \Omega$ |
| Standard Warranty: | 5 Years |
| Fixations: | Concrete screw, Zinc coated, Size $\varnothing 12 \times 80$ mm |
| Deflection zone: | 250mm / 9,84in |

IMPACT TEST

| | | |
|-------------------------------------|--------|--------|
| Mid Rail Max. Energy (Joules) | 90° | 45° |
| | 15.000 | 30.000 |
| End post max. energy (Joules) - 90° | | 4.000 |
| Mid post max. energy (Joules) - 90° | | 4.000 |

MAX. FORCE TO BOLT

LIMA: 21 kN

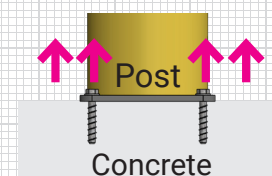

ASSETS AND AUTOMATION



TRAFFIC BARRIER

The Traffic Barrier preserves assets and operational flow by preventing vehicles from colliding with critical infrastructure. It effectively reduces impact exposure for various facilities, including machinery, fluid tanks, control panels, conveyor systems, and walls.

Made of flexible polyethylene, the barrier absorbs impacts by bending and returning to its original shape. Its elasticity allows repeated impacts while reducing pressure on concrete flooring, helping prevent costly repairs and downtime.

TECHNICAL INFORMATION

| | |
|--------------------------------------|--|
| Operational Temperature Range: | -40°C up to +50°C / -40°F up to +112°F |
| Ignition Temperature: | 350-360°C / 662 - 680°F |
| Flash Point: | 350-360°C / 662 - 680°F |
| Toxicity: | Nontoxic |
| Chemical Resistance: | High-ISO / TR 10358 |
| UV Stability | Gray scale: 5/5 |
| Changes to material after 5 years: | Blue Wool scale: 8/8 Tensile strength: No changes |
| Static Rating (surface resistivity): | 10^{15} - $10^{16} \Omega$ |
| Standard Warranty: | 5 Years |
| Fixations: | Concrete screw, Zinc coated, Size $\varnothing 12 \times 80$ mm |
| Deflection zone: | 250mm / 9,84in |

IMPACT TEST

| | | |
|-------------------------------------|-------|--------|
| Mid Rail Max. Energy (Joules) | 90° | 45° |
| | 9.000 | 18.000 |
| End post max. energy (Joules) - 90° | | 4.000 |
| Mid post max. energy (Joules) - 90° | | 4.000 |

MAX. FORCE TO BOLT

CHARLIE: 21 kN

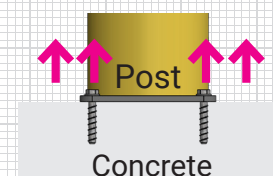



TRAFFIC BARRIER DOUBLE

The Traffic Barrier Double protects assets and infrastructure from impacts with heavy-duty traffic, preserving value and operational flow. It is suited for environments with industrial vehicles such as yard tractors and shunt trucks.

Made of flexible polyethylene, the barrier absorbs impacts by bending and returning to its original shape. Its elasticity allows repeated impacts while reducing pressure on concrete flooring, helping prevent costly repairs and downtime.

TECHNICAL INFORMATION

| | |
|--|---|
| Operational Temperature Range: | -40°C up to +50°C / -40°F up to +112°F |
| Ignition Temperature: | 350-360°C / 662 - 680°F |
| Flash Point: | 350-360°C / 662 - 680°F |
| Toxicity: | Nontoxic |
| Chemical Resistance: | High-ISO / TR 10358 |
| UV Stability Changes to material after 5 years: | Gray scale: 5/5 Blue Wool scale: 8/8 Tensile strength: No changes |
| Static Rating (surface resistivity): | 10^{15} - $10^{16} \Omega$ |
| Standard Warranty: | 5 Years |
| Fixations: | Concrete screw, Zinc coated, Size $\varnothing 12 \times 80$ mm |
| Deflection zone: | 250mm / 9,84in |

IMPACT TEST

| | | |
|-------------------------------------|--------|--------|
| Mid Rail Max. Energy (Joules) | 90° | 45° |
| | 15.000 | 30.000 |
| End post max. energy (Joules) - 90° | | 4.000 |
| Mid post max. energy (Joules) - 90° | | 4.000 |

MAX. FORCE TO BOLT

HOTEL: 21 kN

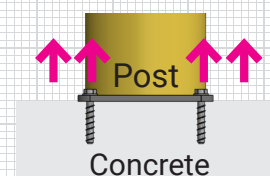

RACKS AND STORAGE



*tested impact energy according to TÜV. TÜV certified and compliant with DIN EN 15512, DIN EN 15635 and the Australian standard AS 4084.



RACK GUARD

The Rack Guard is an essential warehousing solution for maintaining racking system integrity and preventing costly and hazardous collapses. It is widely used in logistics environments where reach trucks, order pickers, and side loaders constantly operate alongside racking systems. This cost-efficient solution installs directly onto the rack without tools or ground anchorage.

TECHNICAL INFORMATION

| | |
|--------------------------------------|--|
| Operational Temperature Range: | -40°C up to +50°C / -40°F up to +112°F |
| Ignition Temperature: | 350-360°C / 662 - 680°F |
| Flash Point: | 350-360°C / 662 - 680°F |
| Toxicity: | Nontoxic |
| Chemical Resistance: | High-ISO / TR 10358 |
| UV Stability | Gray scale: 5/5 |
| Changes to material after 5 years: | Blue Wool scale: 8/8 Tensile strength: No changes |
| Static Rating (surface resistivity): | 10^{15} - $10^{16} \Omega$ |
| Standard Warranty: | 1 Year |

HOW TO CHOOSE

When selecting the ideal RackGuard profile for your pallet racking system, it's essential to choose the right size and width to ensure maximum protection and a secure fit.

RackGuard profiles come in two standard lengths, 400mm and 600mm, providing options for various rack heights.

Additionally, the profiles are available in two width ranges: 75-99mm and 100-125mm, allowing you to match them perfectly to the dimensions of your upright legs.



RACK-END BARRIER

The Rack-End Barrier maintains operational flow and prevents costly downtime and repairs by protecting storage systems and inventory from vehicle impacts. Installed at the ends of racks, it helps forklifts and trucks safely enter and exit aisles. A rotating steel cuff is mounted on the barrier posts to improve durability against repeated light vehicle contact.

Made of flexible polyethylene, the barrier absorbs impacts by bending and returning to its original shape. Its elasticity allows repeated impacts while reducing pressure on concrete flooring, helping prevent costly repairs and downtime.

TECHNICAL INFORMATION

| | |
|--|---|
| Operational Temperature Range: | -40°C up to +50°C / -40°F up to +112°F |
| Ignition Temperature: | 350-360°C / 662 - 680°F |
| Flash Point: | 350-360°C / 662 - 680°F |
| Toxicity: | Nontoxic |
| Chemical Resistance: | High-ISO / TR 10358 |
| UV Stability Changes to material after 5 years: | Gray scale: 5/5 Blue Wool scale: 8/8 Tensile strength: No changes |
| Static Rating (surface resistivity): | 10 ¹⁵ -10 ¹⁶ Ω |
| Standard Warranty: | 5 Years |
| Fixations: | Concrete screw, Zinc coated, Size Ø12x80 mm |
| Deflection zone: | 250mm / 9,84in |

IMPACT TEST

| | | |
|----------------------------------|-------|--------|
| Mid Rail Max. Energy (Joules) | 90° | 45° |
| | 7.000 | 14.000 |

End post max. energy (Joules) - 90° 4.000

MAX. FORCE TO BOLT

GOLF: 21 kN

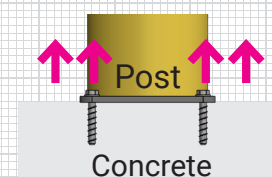

RACKS AND STORAGE



TOPPLE BARRIER

The Topple Barrier maintains operational flow and prevents costly downtime and repairs by separating driving lanes and racking systems. It is ideally positioned where forklifts operate alongside storage structures, safeguarding inventory from impacts and preventing goods from falling. This modular system, built from stackable units, allows customised length and height, up to 4.2 metres.

Made of flexible polyethylene, the barrier absorbs impacts by bending and returning to its original shape. Its elasticity allows repeated impacts while reducing pressure on concrete flooring, helping prevent costly repairs and downtime.

TECHNICAL INFORMATION

| | |
|--------------------------------------|--|
| Operational Temperature Range: | -40°C up to +50°C / -40°F up to +112°F |
| Ignition Temperature: | 350-360°C / 662 - 680°F |
| Flash Point: | 350-360°C / 662 - 680°F |
| Toxicity: | Nontoxic |
| Chemical Resistance: | High-ISO / TR 10358 |
| UV Stability | Gray scale: 5/5 |
| Changes to material after 5 years: | Blue Wool scale: 8/8 Tensile strength: No changes |
| Static Rating (surface resistivity): | 10^{15} - 10^{16} Ω |
| Standard Warranty: | 5 Years |
| Fixations: | Concrete screw, Zinc coated, Size Ø12x80 mm |
| Deflection zone: | 250mm / 9,84in |

IMPACT TEST

| | | |
|----------------------------------|-------|--------|
| Mid Rail Max. Energy (Joules) | 90° | 45° |
| | 9.000 | 18.000 |

End post max. energy (Joules) - 90° 4.000

Mid post max. energy (Joules) - 90° 4.000

MAX. FORCE TO BOLT

QUEBEC: 21 kN

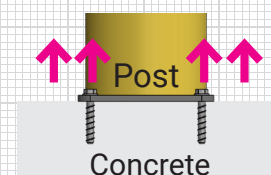

GATEWAYS

REDUCE GATEWAY EXPOSURE TO TRAFFIC



BOLLARD

The Bollard prevents downtime and costly repairs by protecting infrastructure from vehicle impacts. It safeguards vulnerable edges, corners, and gateways in warehouses and production facilities. Easy to install, these highly visible yellow bollards help prevent accidents by improving driver awareness.

TECHNICAL INFORMATION

| | |
|--------------------------------------|--|
| Operational Temperature Range: | -40°C up to +50°C / -40°F up to +112°F |
| Ignition Temperature: | 350-360°C / 662 - 680°F |
| Flash Point: | 350-360°C / 662 - 680°F |
| Toxicity: | Nontoxic |
| Chemical Resistance: | High-ISO / TR 10358 |
| UV Stability | Gray scale: 5/5 |
| Changes to material after 5 years: | Blue Wool scale: 8/8 Tensile strength: No changes |
| Static Rating (surface resistivity): | 10^{15} - $10^{16} \Omega$ |
| Standard Warranty: | 5 Years |
| Fixations: | Concrete screw, Zinc coated, Size $\varnothing 12 \times 80$ mm |

IMPACT TEST

Bollard max. energy 6.500

MAX. FORCE TO BOLT

BRAVO: 21 kN

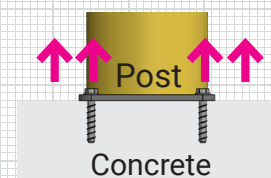

MAX. INCLINATION ANGLE 15°

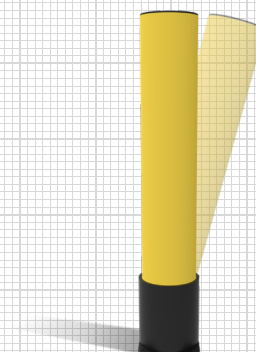

GATEWAYS

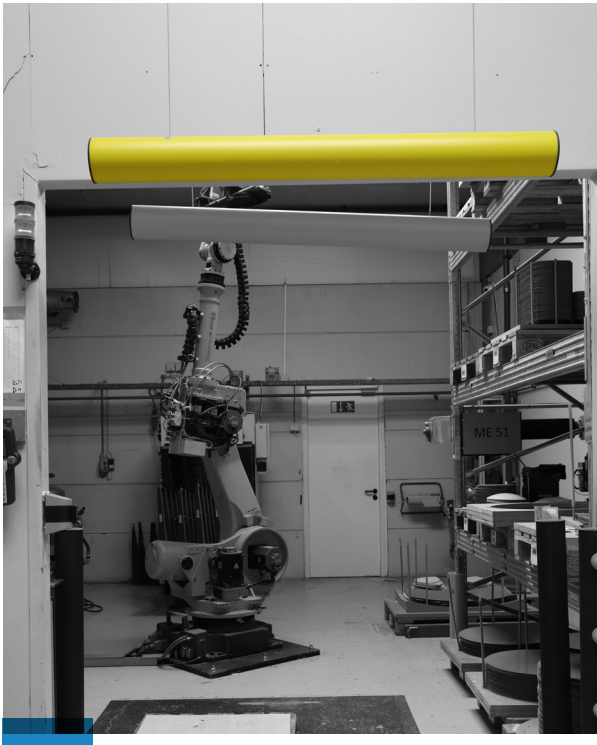

HANGING BAR

The Hanging Bar supports smooth material handling by visually marking gateways and dock gates. Its ceiling suspension enables fast installation at crossing points and in loading bays. This protection effectively combines with bollards to preserve vital infrastructure, minimising costly repairs and downtime.

TECHNICAL INFORMATION

| | |
|--------------------------------------|--|
| Operational Temperature Range: | -40°C up to +50°C / -40°F up to +112°F |
| Ignition Temperature: | 350-360°C / 662 - 680°F |
| Flash Point: | 350-360°C / 662 - 680°F |
| Toxicity: | Nontoxic |
| Chemical Resistance: | High-ISO / TR 10358 |
| UV Stability | Gray scale: 5/5 |
| Changes to material after 5 years: | Blue Wool scale: 8/8 Tensile strength: No changes |
| Static Rating (surface resistivity): | 10^{15} - 10^{16} Ω |
| Standard Warranty: | 5 Years |



HEIGHT RESTRICTOR

The Height Restrictor prevents downtime and costly repairs by safeguarding gateways from vehicle impacts. It enables effective lintel and jamb protection in settings where hanging guards cannot be suspended from the ceiling. This highly visible yellow structure also improves driver awareness by clearly marking gateways.

TECHNICAL INFORMATION

| | |
|--------------------------------------|--|
| Operational Temperature Range: | -40°C up to +50°C / -40°F up to +112°F |
| Ignition Temperature: | 350-360°C / 662 - 680°F |
| Flash Point: | 350-360°C / 662 - 680°F |
| Toxicity: | Nontoxic |
| Chemical Resistance: | High-ISO / TR 10358 |
| UV Stability | Gray scale: 5/5 |
| Changes to material after 5 years: | Blue Wool scale: 8/8 Tensile strength: No changes |
| Static Rating (surface resistivity): | 10^{15} - $10^{16} \Omega$ |
| Standard Warranty: | 5 Years |
| Fixations: | Concrete screw, Zinc coated, Size $\varnothing 12 \times 80$ mm |

MAX. FORCE TO BOLT

SIERRA: 21 kN

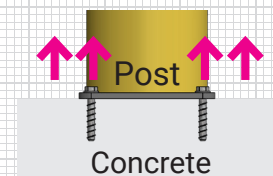

WALLS AND COLUMNS



KERB GUARD

The Kerb Guard improves material-handling operations by preventing vehicle forks and loads from damaging walls and structures. It is commonly installed along walls, preventing repeated impacts from compromising building integrity. Kerb Guards can also supplement a Pedestrian Guardrail or Barrier by blocking ground-level hazards from passing beneath.

TECHNICAL INFORMATION

| | |
|--------------------------------------|---|
| Operational Temperature Range: | -40°C up to +50°C / -40°F up to +112°F |
| Ignition Temperature: | 350-360°C / 662 - 680°F |
| Flash Point: | 350-360°C / 662 - 680°F |
| Toxicity: | Nontoxic |
| Chemical Resistance: | High-ISO / TR 10358 |
| UV Stability | Gray scale: 5/5 |
| Changes to material after 5 years: | Blue Wool scale: 8/8 Tensile strength: No changes |
| Static Rating (surface resistivity): | 10^{15} - $10^{16} \Omega$ |
| Standard Warranty: | 5 Years |
| Fixations: | Concrete screw, Zinc coated, Size $\varnothing 12 \times 110$ mm |
| Deflection zone: | 250mm / 9,84in |

MAX. FORCE TO BOLT

MIKE: 21 kN

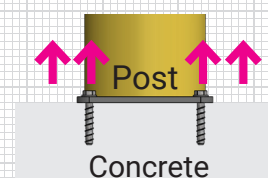



COLUMN PROTECTOR

The Column Protector minimises damage to vital infrastructure by providing impact protection against vehicles. It is applied directly to columns in traffic-heavy environments, such as storage areas and loading bays. Modular design and straps enable fast tool-free installation without floor anchoring.

TECHNICAL INFORMATION

| | |
|--------------------------------|-------------------|
| Material: | Polyethylene |
| Operational Temperature Range: | -15°C up to +40°C |
| Toxicity: | Nontoxic |
| Area of application: | Indoor |
| Width (mm): | 800 |
| Height (mm): | 1080 |
| Depth (mm): | 180 |
| Fixing included: | Velcro |

IMPACT TEST

| | | |
|----------------------------------|-------|-------|
| Mid Rail Max. Energy (Joules) | 90° | 45° |
| | 2.100 | 3.100 |

LOADING BAYS AND DOCK GATES

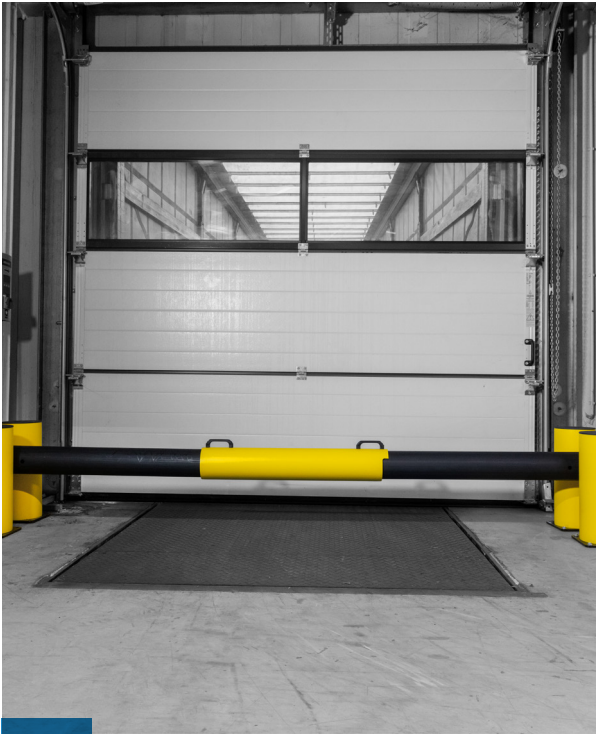

DOCK GATE

The Dock Gate secures material handling in loading bays by reducing the risk of forklift tipping at dock edges. A retaining spring enables a single person to easily open and close it during loading operations. It also protects sliding doors from vehicle impact, preventing costly repairs and downtime.

TECHNICAL INFORMATION

| | |
|--------------------------------------|--|
| Operational Temperature Range: | -40°C up to +50°C / -40°F up to +112°F |
| Ignition Temperature: | 350-360°C / 662 - 680°F |
| Flash Point: | 350-360°C / 662 - 680°F |
| Toxicity: | Nontoxic |
| Chemical Resistance: | High-ISO / TR 10358 |
| UV Stability | Gray scale: 5/5 |
| Changes to material after 5 years: | Blue Wool scale: 8/8 Tensile strength: No changes |
| Static Rating (surface resistivity): | 10^{15} - $10^{16} \Omega$ |
| Standard Warranty: | 5 Years |
| Fixations: | Concrete screw, Zinc coated, Size $\varnothing 12 \times 80$ mm |
| Deflection zone: | 250mm / 9,84in |

IMPACT TEST

| | | |
|-------------------------------------|-------|-------|
| Mid Rail Max. Energy (Joules) | 90° | 45° |
| | 4.500 | 9.000 |
| End post max. energy (Joules) - 90° | | 4.000 |

MAX. FORCE TO BOLT

NOVEMBER: 21 kN

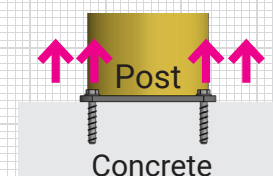



WHEEL GUIDE

The Wheel Guide smooths loading and unloading operations by improving truck alignment with dock gates. It is ideal in logistics hubs with frequent truck docking and limited manoeuvring space. Made of robust polyethylene, it offers a low-maintenance solution capable of withstanding repeated contact and abrasion.

TECHNICAL INFORMATION

| | |
|--------------------------------------|--|
| Operational Temperature Range: | -40°C up to +50°C / -40°F up to +112°F |
| Ignition Temperature: | 350-360°C / 662 - 680°F |
| Flash Point: | 350-360°C / 662 - 680°F |
| Toxicity: | Nontoxic |
| Chemical Resistance: | High-ISO / TR 10358 |
| UV Stability | Gray scale: 5/5 |
| Changes to material after 5 years: | Blue Wool scale: 8/8 Tensile strength: No changes |
| Static Rating (surface resistivity): | 10^{15} - 10^{16} Ω |
| Standard Warranty: | 5 Years |
| Deflection zone: | 250mm / 9,84in |

OUR PROJECTS

At d-flexx, we believe that the best proof of our quality and commitment comes from those who work with our products every day. From warehouse managers to safety officers, our customers trust d-flexx to deliver reliable, flexible, and effective safety solutions. Here's what they have to say about their experience with us.



HERMES DEUTSCHLAND

HERMES Einrichtungs Service is a leading logistics provider specializing in the delivery and assembly of furniture, appliances, and other large goods. With decades of experience and a strong network across Central Europe, the company offers end-to-end services tailored to the needs of retailers and their customers.

"With d-flexx, our operations run more smoothly and we prevent minor accident-related costs, which saves money." Warehouse Manager at HERMES Einrichtungs Service – Germany



AP GRØNT

AP Grønt is a major Danish producer of leafy greens and baby leaves, supplying both the domestic and export markets. Based in Zealand, the company has grown steadily since 1978, focusing on large-scale, year-round production. Their operations meet key food safety and sustainability standards, serving retail and foodservice with both conventional and organic products.

"Before, we had a lot of damages, which cost us not only a lot of money but also a lot of time. Our experience shows that after we got d-flexx installed almost everywhere, the damages have almost disappeared." CEO at AP Grønt, Denmark



GEODIS

Geodis is a global logistics leader with a strong footprint in the Nordics, offering freight forwarding, contract logistics, and distribution services. They combine international scale with local expertise, serving key industries across the region. Their operations are structured, tech-driven, and focused on performance, making them a central player in the Nordic logistics landscape.

"The d-flexx Designer is a real asset. It allowed me to plan the project around my needs and vision. This flexibility reflects d-flexx's professionalism." Warehouse Manager at GEODIS – Sweden



PACKOPLOCK SCANDINAVIA

Packoplock is a Swedish packaging wholesaler established in 2007 and based in Norrköping. They supply transport and retail packaging, as well as cleaning and office supplies. Their operations rely on a well-developed warehouse infrastructure to manage a broad product range and high order volumes.

"By implementing d-flexx materials with their bright colours, we improved circulation and reduced disturbances on forklift paths. The feedback has been clear: people feel noticeably safer." Product Manager at PACKOPLOCK – Sweden

MAKING YOUR WORLD SAFE



PART OF TROAX GROUP